

TVQ DF10 04 AD0 Engineering Specification

1. Scope

TVQ DF10 04 AD0's are TVS arrays designed to protect power/control lines and high-speed signal lines from overvoltage hazard of Electrostatic Discharge (**ESD**), Electrical Fast Transients (**EFT**) and **Lightning**. These interfaces can be used for **high definition multi-media interface (HDMI)** at 1.65 Gb/s and up to 3.2 Gb/s, digital visual interface (DVI), USB3.0 power and data lines protection, notebook and personal computers, monitors and flat panel displays, IEEE 1394 Firewire Ports, etc.

TVQ DF10 04 AD0 incorporates a pair of rail-to-rail diodes with low capacitance for each of four I/O channels. Additional Zener diode is employed to minimize the influence of supply voltage. The ESD protection of TVS arrays meets the immunity standard of IEC 61000-4-2, level 4 ($\pm 15\text{kV}$ air, $\pm 8\text{kV}$ contact discharge).

2. Explanation of Part Number

<u>TV</u>	<u>Q</u>	<u>DF10</u>	<u>04</u>	<u>AD0</u>
(1)	(2)	(3)	(4)	(5)

- (1) Product Type : TV=TVS Diode
- (2) Capacitance Code : Q=Ultra Low Capacitance
- (3) Package Size Code
- (4) Channel Code : 04=4 Channels
- (5) Specialized Specification Code

3. Circuit Diagram /Pin Configuration

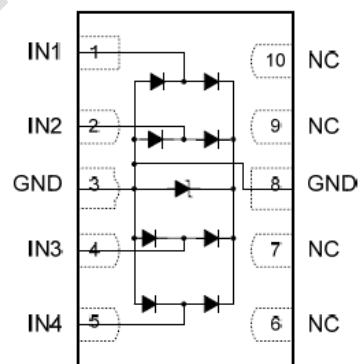

**Circuit Diagram
DFN-10 (Top-view)**

4. Specifications

4.1. ABSOLUTE MAXIMUM RATINGS

Parameter	Symbol	Typical	Unit
Peak Pulse Power ($t_p = 8/20 \mu s$)	P_{pk}	150	W
Maximum Peak Pulse Current ($t_p = 8/20 \mu s$)	I_{pp}	5	A
ESD per IEC 61000 – 4 – 2 (Air)	V_{ESD1}	± 15	KV
ESD per IEC 61000 – 4 – 2 (Contact)	V_{ESD2}	± 8	KV
Operating Junction Temperature	T_{OPR}	-55 ~ 125	$^{\circ}C$
Storage Temperature Range	T_{STG}	-55 ~ 150	$^{\circ}C$
Lead Soldering Temperature	TL	260 (10sec)	$^{\circ}C$

4.2. ELECTRICAL CHARACTERISTICS (T=25 $^{\circ}C$)

PARAMETER	SYMBOL	CONDITIONS	MIN	TYP	MAX	UNITS
Reverse Stand-Off Voltage	V_{RWM}	Any I/O pin to Ground			5	V
Reverse Leakage Current	I_{Leak}	$V_{RWM} = 5V$, Any I/O pin to Ground			1	A
Forward Voltage @ IF	V_F	$I_F = 10mA$	0.4	0.8	1.5	V
Reverse Breakdown Voltage	V_{BV}	$I_{BV} = 1mA$, Any I/O pin to Ground	6	7		V
ESD Clamping Voltage –I/O	V_{C1}	$I_{PP}=1A$, $t_p=8/20\mu S$, Any I/O pin to Ground		8.5	12	V
Reverse ESD Clamping Voltage –I/O	V_{C2}	$I_{PP}=1A$, $t_p=8/20\mu S$, Any I/O pin to Ground		1.8		V
Channel to Channel Input Capacitance	C_{J1}	$V_R=0V$, $f=1MHz$, Between I/O pins		0.2	0.25	pF
Channel I/O to GND Capacitance	C_{J2}	$V_R=0V$, $f=1MHz$, Any I/O pin to Ground		0.35	0.4	pF

4.3. TYPICAL CHARACTERISTICS

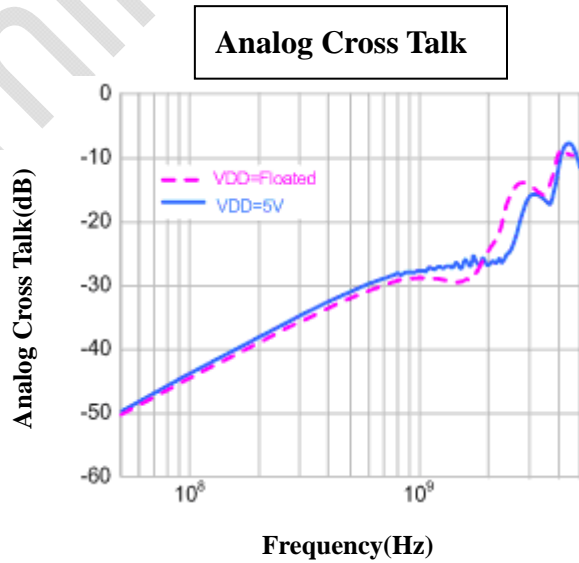
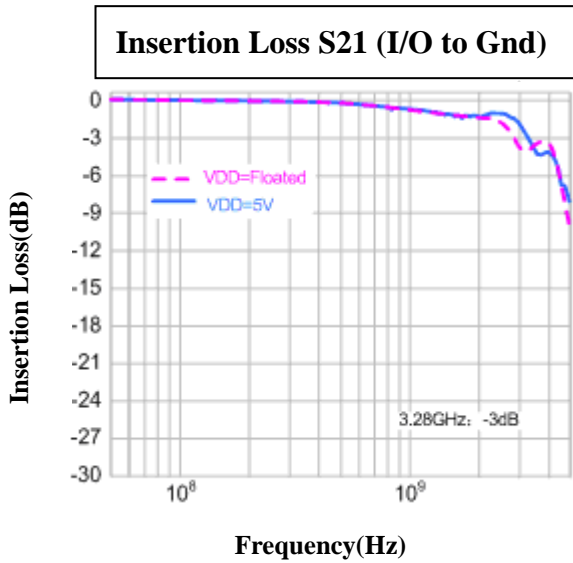
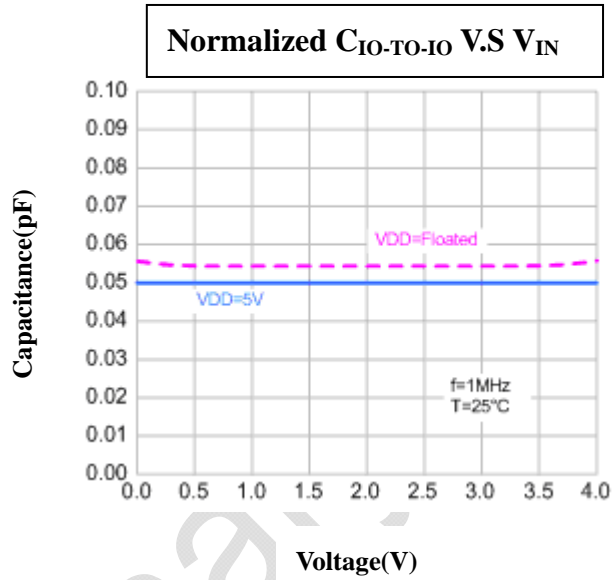
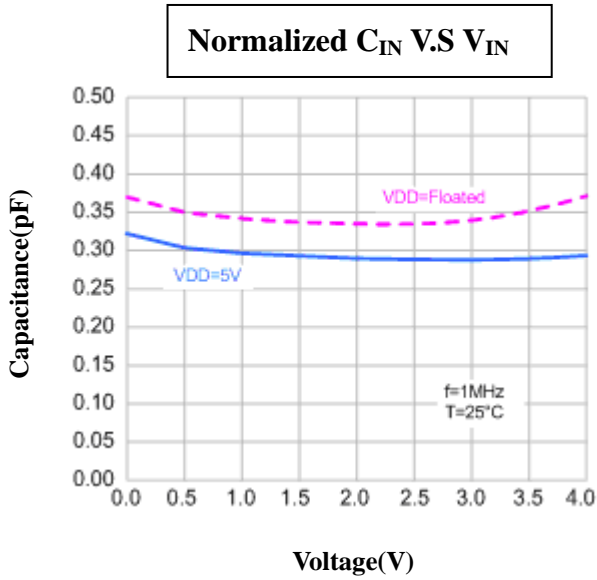

Transmission Line Pulsing (TLP)

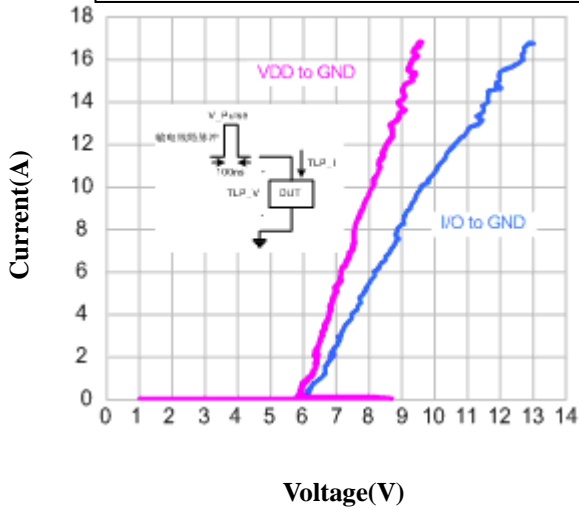

5.Land Layout

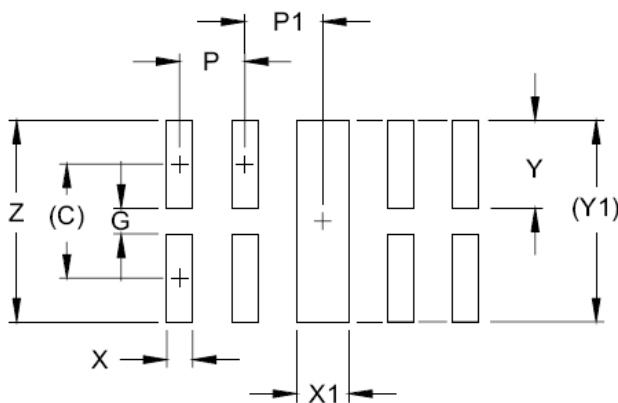

DIMENSIONS		
DIM	INCHES	MILLIMETERS
C	(.034)	(0.875)
G	.008	0.20
P	.020	0.50
P1	.020	0.50
X	.008	0.20
X1	.016	0.40
Y	.027	0.675
Y1	(.061)	(1.55)
Z	.061	1.55

NOTES:

1. CONTROLLING DIMENSIONS ARE IN MILLIMETERS (ANGLES IN DEGREES).
2. THIS LAND PATTERN IS FOR REFERENCE PURPOSES ONLY. CONSULT YOUR MANUFACTURING GROUP TO ENSURE YOUR COMPANY'S MANUFACTURING GUIDELINES ARE MET.

6. MARKING CODE:



YW=Date Code (Y=Year,W=Week)
Q=Specific Device Code

7. Mechanical Details

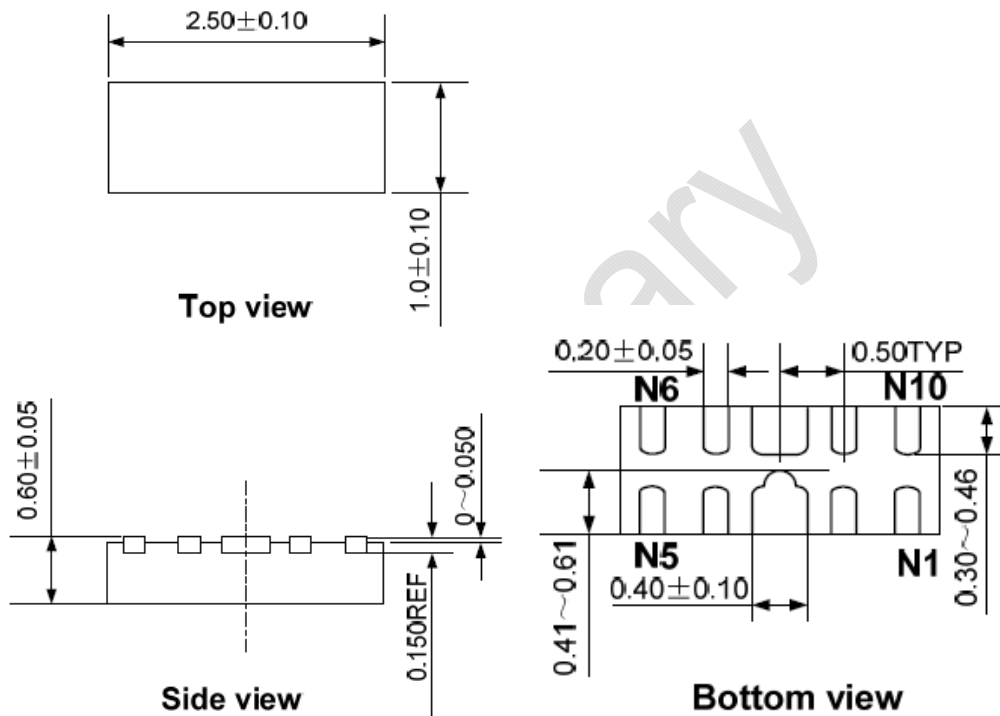

7.1. Taping Quantity:

3,000pcs/ Reel (for 7" Reel)